

G^oDⁱFF IMPLANT SYSTEM

SURGICAL MANUAL

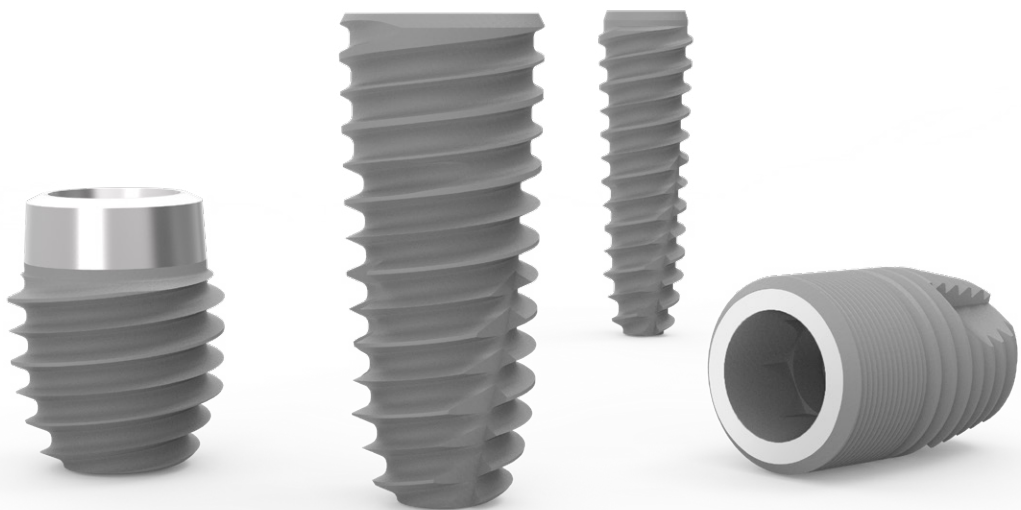

G^oDIFF
GENUINE DIFFERENCE

G·DIFF Implant System

Contents







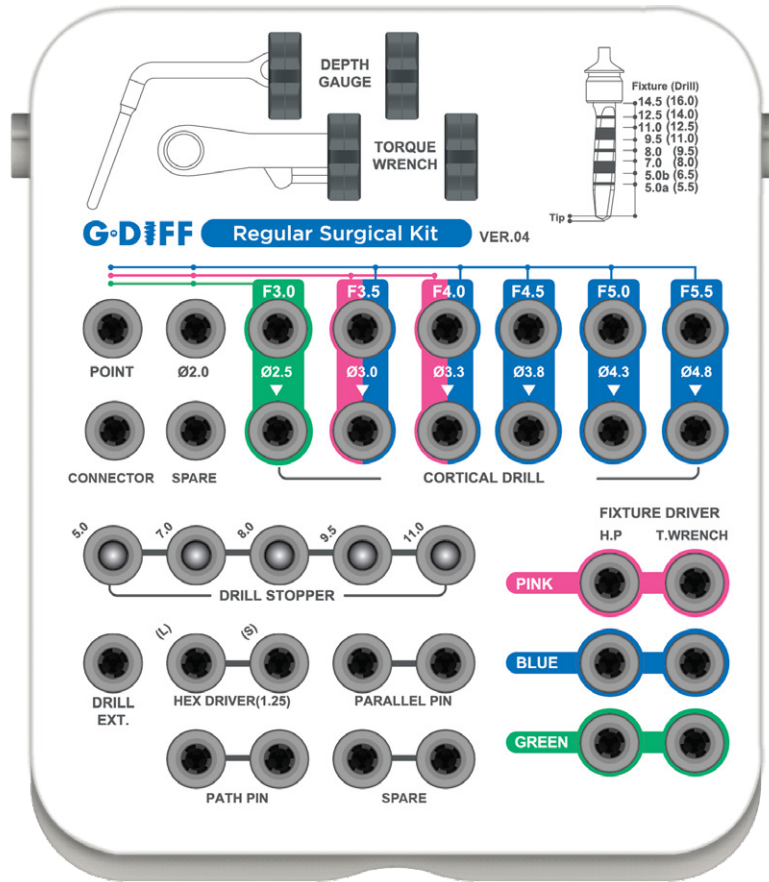



Surgical procedures for utilizing G·DIFF implant system

G·DIFF Regular Surgical Kit	4
Drilling Sequence Overview	5
Drilling Sequence Guide	6
Drilling Protocol	7
Ø3.0x9.5mm	7
Ø3.5x9.5mm	7
Ø4.0x9.5mm	8
Ø4.5x9.5mm	8
Ø5.0x9.5mm	9
Ø5.5x9.5mm	9
Implant Installation	10
G·DIFF Advanced Surgical Kit	14
Drilling Protocol	15
Ø3.0x9.5mm	15
Ø3.5x9.5mm	15
Ø4.0x9.5mm	16
Ø4.5x9.5mm	16
Ø5.0x9.5mm	17
Ø5.5x9.5mm	17
G·DIFF Full Surgical Kit	18
Drilling Protocol	19
Ø6.0x9.5mm	19
Ø7.0x9.5mm	19
Pre-Operative Procedures	20
Implants & Drills Overview	21
Implant Package Opening	25
Sterilization and Instrument Care	27

G-DIFF Regular Surgical Kit



Kit Contents



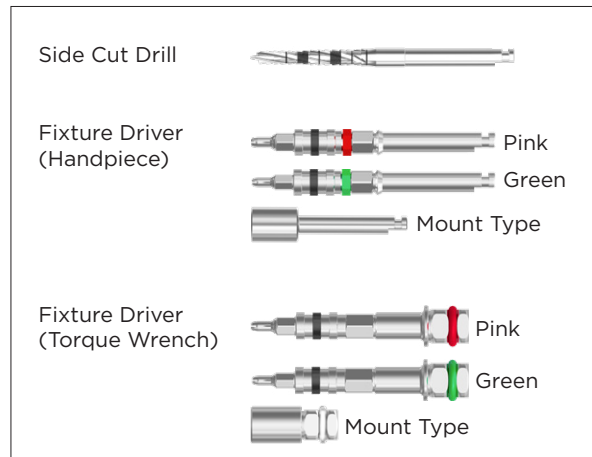

- Point Drill 
- Twist Drill 
(Ø2.0, Ø2.5, Ø3.0, Ø3.3, Ø3.8, Ø4.3, Ø4.8)
- Cortical Drill 
(Ø3.1, Ø3.7, Ø4.2, Ø4.6, Ø5.0, Ø5.5)
- Drill Stopper 
(L5.0, L7.0, L8.0, L9.5, L11.0)
- Fixture Driver (Handpiece) 
- Fixture Driver (Torque Wrench) 
- Hex Driver (1.25) 
(Long, Short)
- Drill Extension 
- Parallel Pin 
- Path Pin 

- Depth Gauge 
- Torque Wrench 

* Optional Item

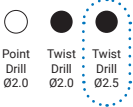
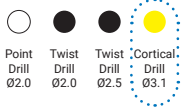
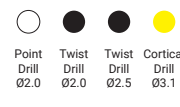

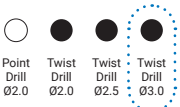
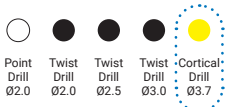
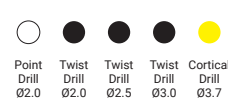
Drilling Sequence Overview -Regular Surgical Kit

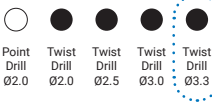
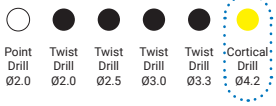
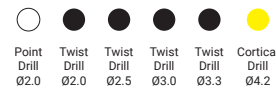
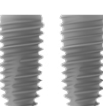
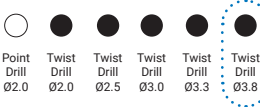
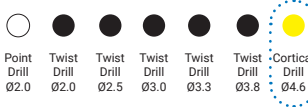
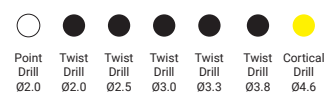
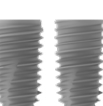
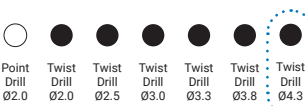
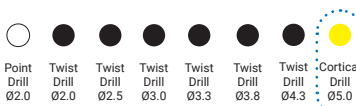
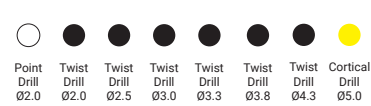
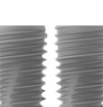
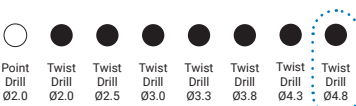
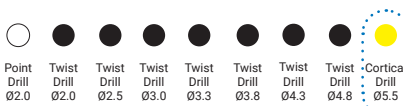
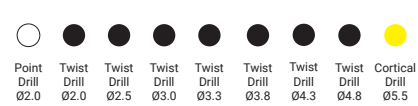
Implants	Drilling Protocol - Soft Bone	Drilling Protocol - Standard Bone	Drilling Protocol - Dense Bone
 <p>IB mini Ø3.0 x 9.5mm</p>	 <p>Point Drill Ø2.0 Twist Drill Ø2.0 Twist Drill Ø2.5</p>	 <p>Point Drill Ø2.0 Twist Drill Ø2.0 Twist Drill Ø2.5 Cortical Drill Ø3.1</p>	 <p>Point Drill Ø2.0 Twist Drill Ø2.0 Twist Drill Ø2.5 Cortical Drill Ø3.1</p>
 <p>IB IB T Ø3.5 x 9.5mm</p>	 <p>Point Drill Ø2.0 Twist Drill Ø2.0 Twist Drill Ø2.5 Twist Drill Ø3.0</p>	 <p>Point Drill Ø2.0 Twist Drill Ø2.0 Twist Drill Ø2.5 Twist Drill Ø3.0 Cortical Drill Ø3.7</p>	 <p>Point Drill Ø2.0 Twist Drill Ø2.0 Twist Drill Ø2.5 Twist Drill Ø3.0 Cortical Drill Ø3.7</p>
 <p>IB IB T Ø4.0 x 9.5mm</p>	 <p>Point Drill Ø2.0 Twist Drill Ø2.0 Twist Drill Ø2.5 Twist Drill Ø3.0 Twist Drill Ø3.3</p>	 <p>Point Drill Ø2.0 Twist Drill Ø2.0 Twist Drill Ø2.5 Twist Drill Ø3.0 Twist Drill Ø3.3 Cortical Drill Ø4.2</p>	 <p>Point Drill Ø2.0 Twist Drill Ø2.0 Twist Drill Ø2.5 Twist Drill Ø3.0 Twist Drill Ø3.3 Cortical Drill Ø4.2</p>
 <p>IB IB T Ø4.5 x 9.5mm</p>	 <p>Point Drill Ø2.0 Twist Drill Ø2.0 Twist Drill Ø2.5 Twist Drill Ø3.0 Twist Drill Ø3.3 Twist Drill Ø3.8</p>	 <p>Point Drill Ø2.0 Twist Drill Ø2.0 Twist Drill Ø2.5 Twist Drill Ø3.0 Twist Drill Ø3.3 Twist Drill Ø3.8 Cortical Drill Ø4.6</p>	 <p>Point Drill Ø2.0 Twist Drill Ø2.0 Twist Drill Ø2.5 Twist Drill Ø3.0 Twist Drill Ø3.3 Twist Drill Ø3.8 Cortical Drill Ø4.6</p>
 <p>IB IB T Ø5.0 x 9.5mm</p>	 <p>Point Drill Ø2.0 Twist Drill Ø2.0 Twist Drill Ø2.5 Twist Drill Ø3.0 Twist Drill Ø3.3 Twist Drill Ø3.8 Twist Drill Ø4.3</p>	 <p>Point Drill Ø2.0 Twist Drill Ø2.0 Twist Drill Ø2.5 Twist Drill Ø3.0 Twist Drill Ø3.3 Twist Drill Ø3.8 Twist Drill Ø4.3 Cortical Drill Ø5.0</p>	 <p>Point Drill Ø2.0 Twist Drill Ø2.0 Twist Drill Ø2.5 Twist Drill Ø3.0 Twist Drill Ø3.3 Twist Drill Ø3.8 Twist Drill Ø4.3 Cortical Drill Ø5.0</p>
 <p>IB IB T Ø5.5 x 9.5mm</p>	 <p>Point Drill Ø2.0 Twist Drill Ø2.0 Twist Drill Ø2.5 Twist Drill Ø3.0 Twist Drill Ø3.3 Twist Drill Ø3.8 Twist Drill Ø4.3 Twist Drill Ø4.8</p>	 <p>Point Drill Ø2.0 Twist Drill Ø2.0 Twist Drill Ø2.5 Twist Drill Ø3.0 Twist Drill Ø3.3 Twist Drill Ø3.8 Twist Drill Ø4.3 Twist Drill Ø4.8 Cortical Drill Ø5.5</p>	 <p>Point Drill Ø2.0 Twist Drill Ø2.0 Twist Drill Ø2.5 Twist Drill Ø3.0 Twist Drill Ø3.3 Twist Drill Ø3.8 Twist Drill Ø4.3 Twist Drill Ø4.8 Cortical Drill Ø5.5</p>

*Note :  Depending on the bone density, Drills may not be used.

Drilling Sequence Guide -Regular Surgical Kit

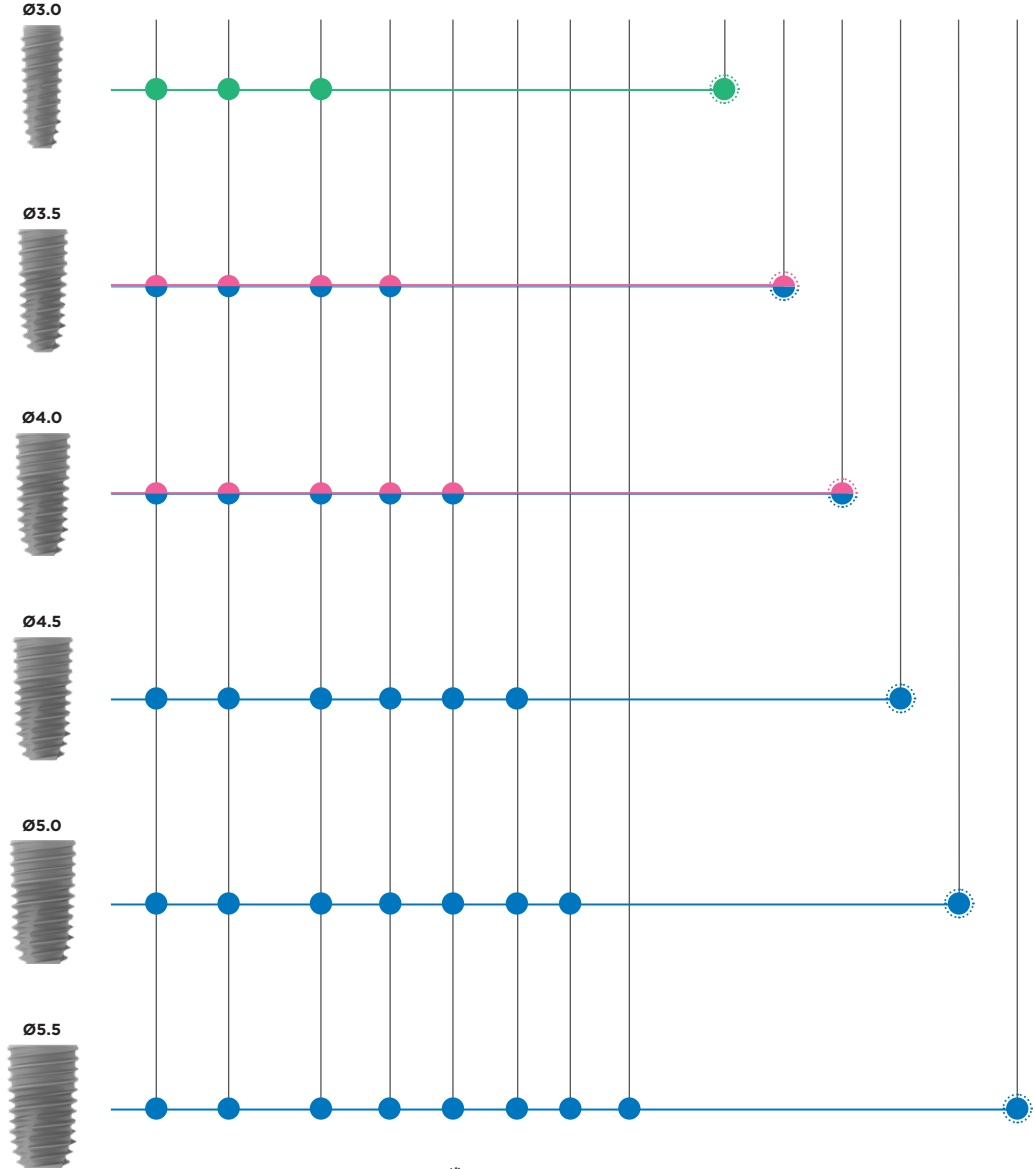
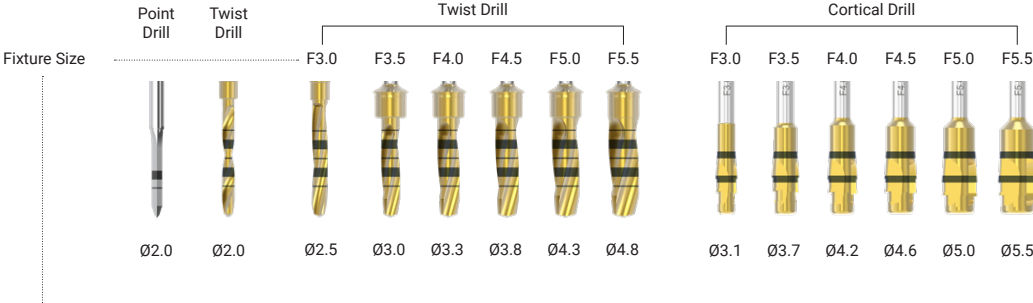

*Note : Depending on the bone density, Drills may not be used.

Drilling Protocol -Regular Surgical Kit

Ø3.0x9.5mm (1,000 RPM / 30~45N·cm)

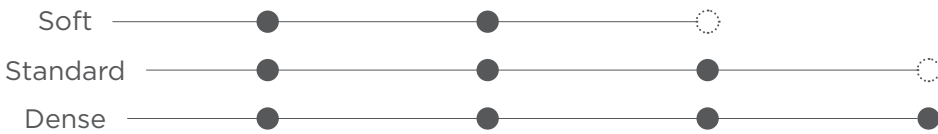
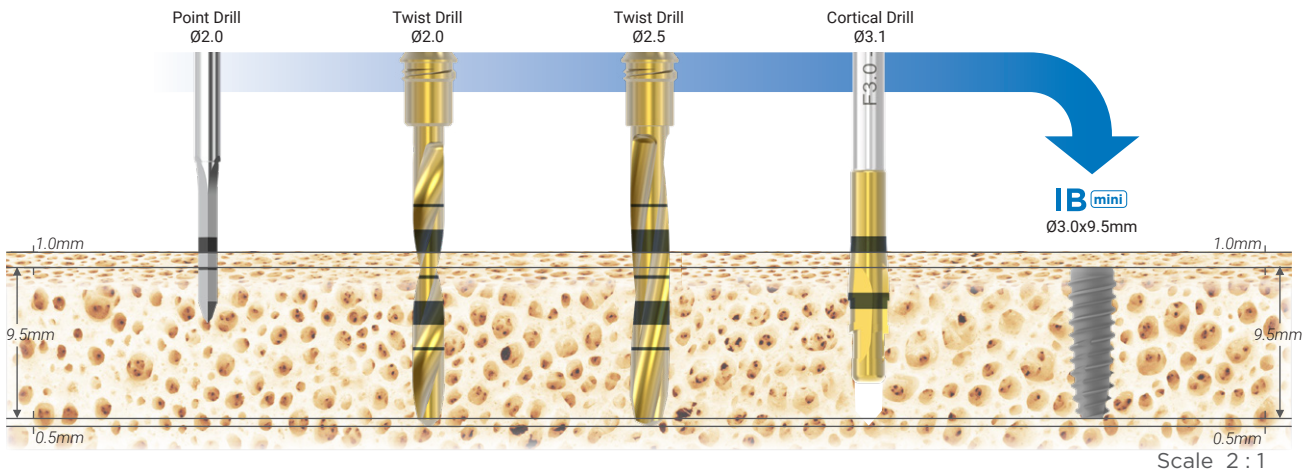

Ø3.5x9.5mm (1,000 RPM / 30~45N·cm)

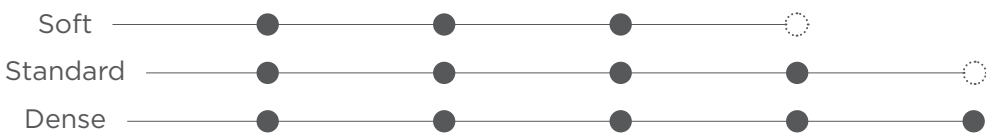
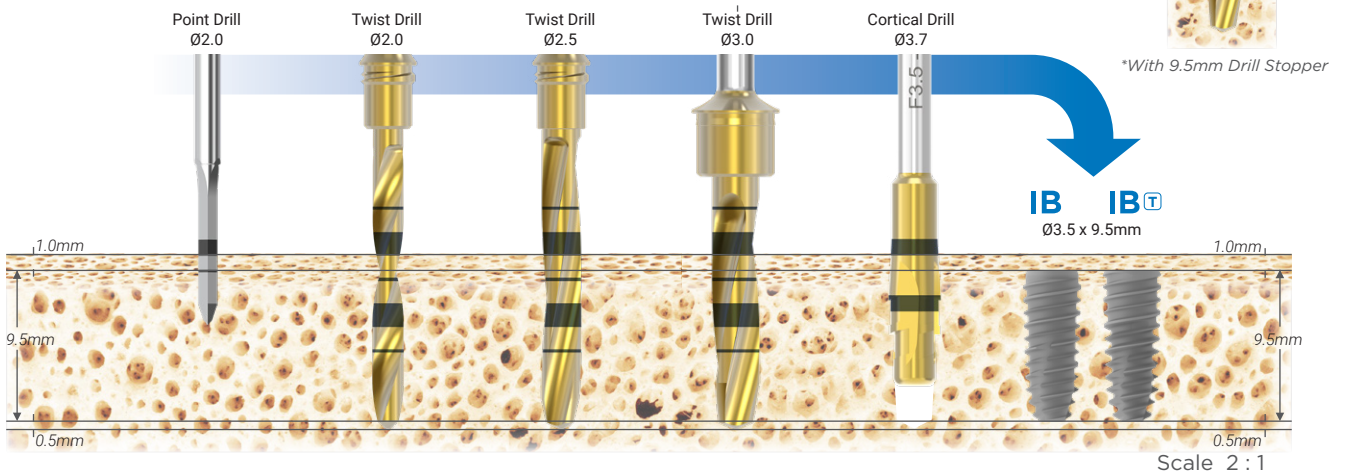

Ø4.0x9.5mm (1,000 RPM / 30~45N·cm)

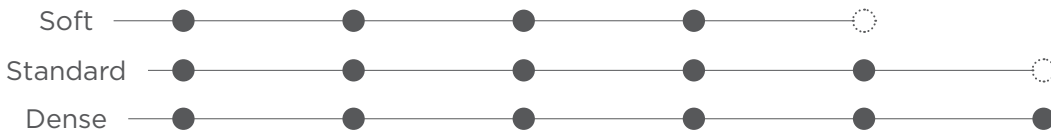
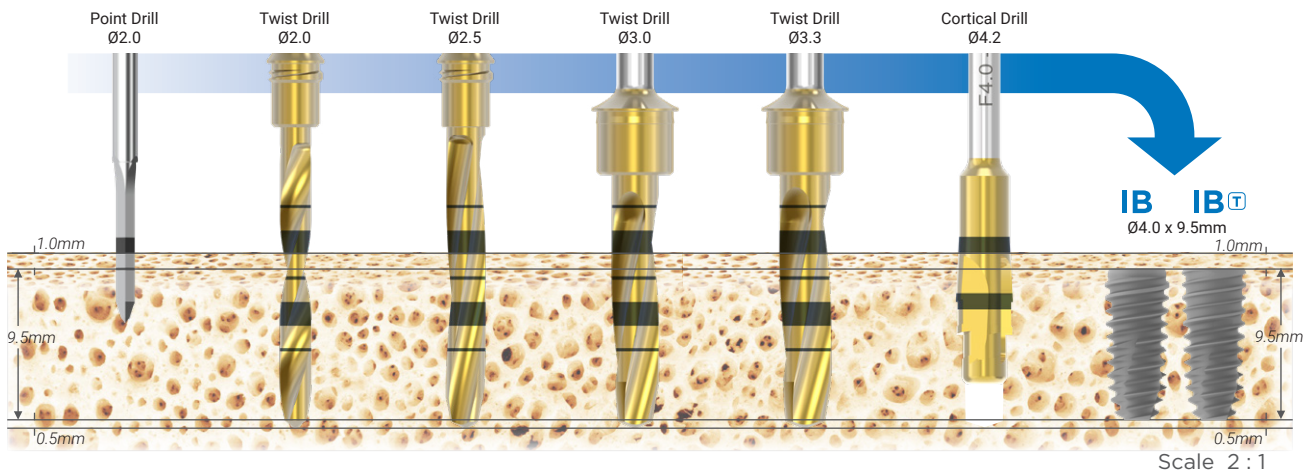

Ø4.5x9.5mm (1,000 RPM / 30~45N·cm)

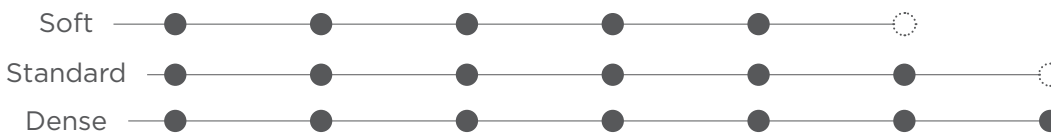
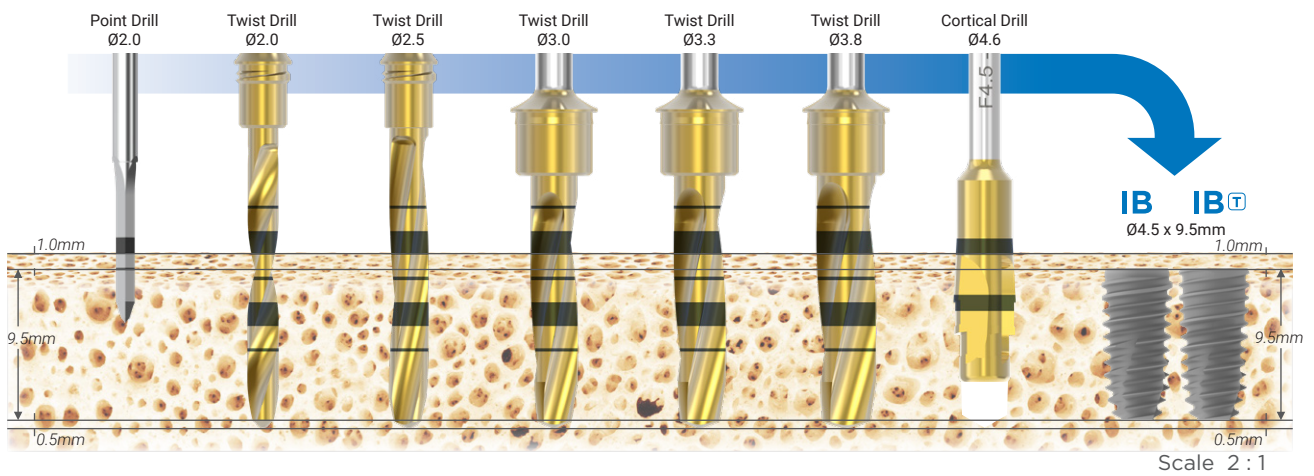

Ø5.0x9.5mm

(1,000 RPM / 30~45N·cm)

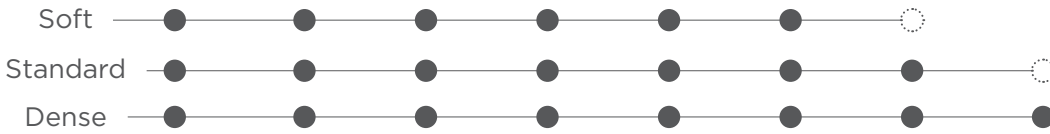
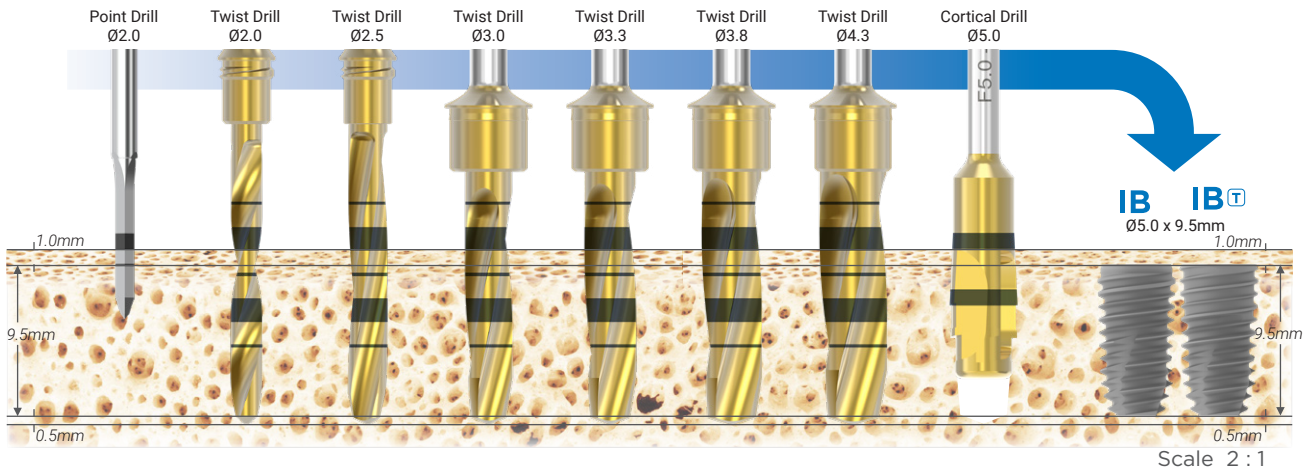

Ø5.5x9.5mm

(1,000 RPM / 30~45N·cm)

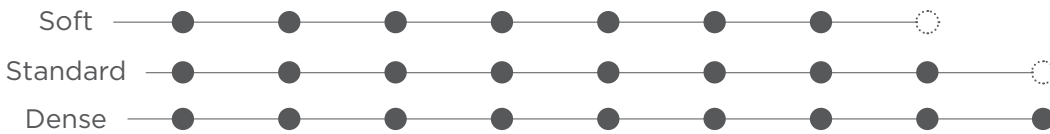
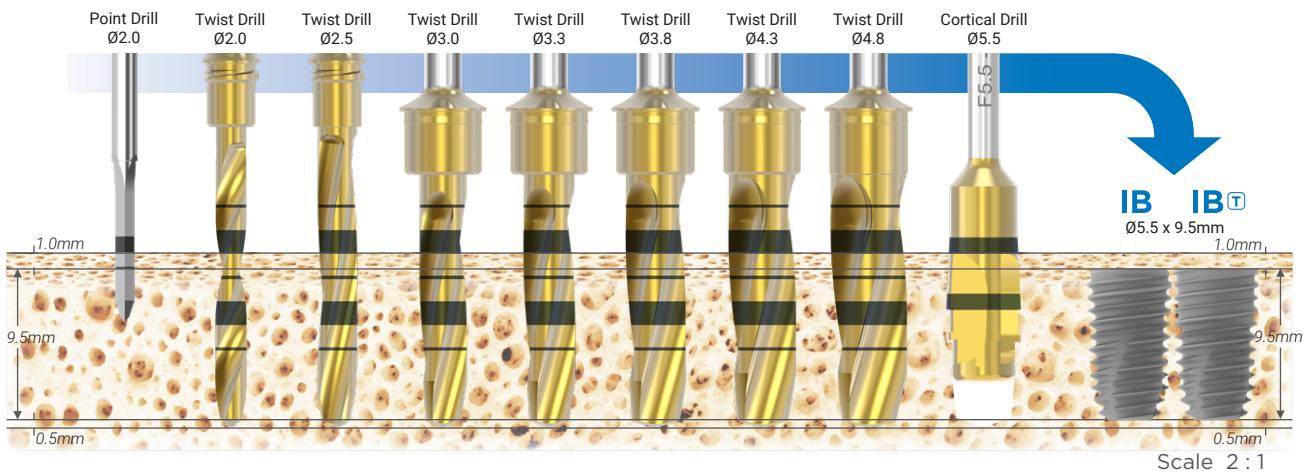

Implant Installation -Regular Surgical Kit

Step-by-step procedures for placement of IB-T implants

The following is an overview of implant site preparation according to the standard drilling protocol for the installation of IB-T implants Ø4.5 and Ø4.0.

Note: All drilling should be performed at 800 to 1,500 rpm with a pumping motion and under external irrigation.

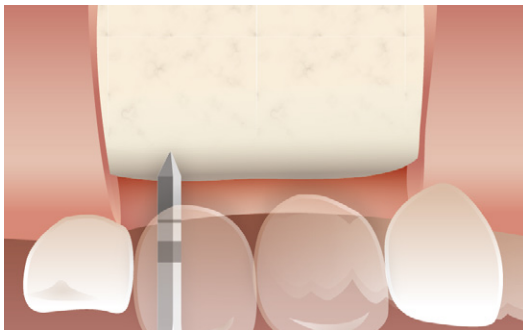
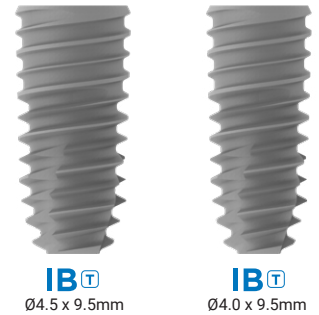

Point Drill

Mark out the planned position of the implant site.

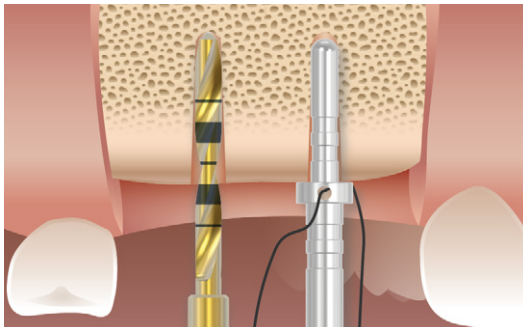

Twist Drill Ø2.0 (Implant Ø4.5 & Ø4.0)

Drill in the planned direction to the appropriate depth.

Insert the Parallel Pin into the site to verify the direction.

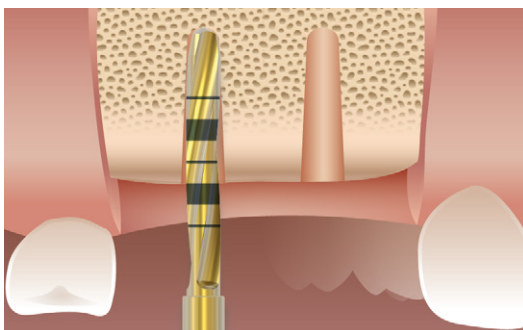

Twist Drill Ø2.5 (Implant Ø4.5 & Ø4.0)

Drill the implant site to the appropriate depth.

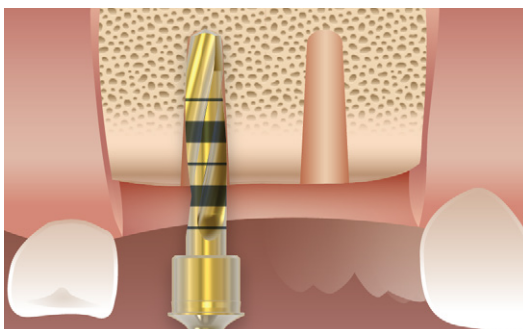

Twist Drill Ø3.0 (Implant Ø4.5 & Ø4.0)

Drill the implant site to the appropriate depth.

*Drill Stopper :

For safe drilling, connect drill stopper with drill.
(Drill diameter : Ø3.0-Ø4.8 only)



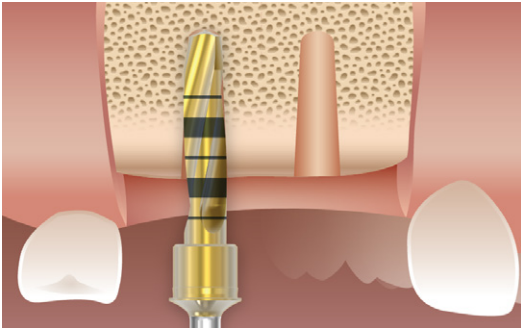

Twist Drill Ø3.3 (Implant Ø4.5 & Ø4.0)
Drill the implant site to the appropriate depth.

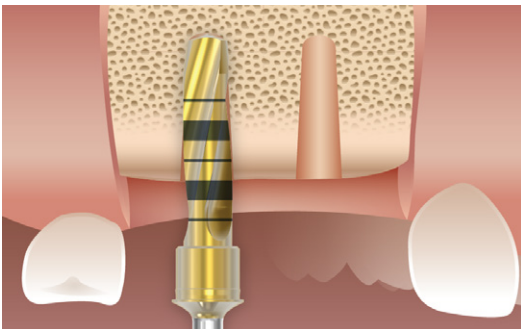

Twist Drill Ø3.8 (Implant Ø4.5)
Drill the implant site to the appropriate depth.

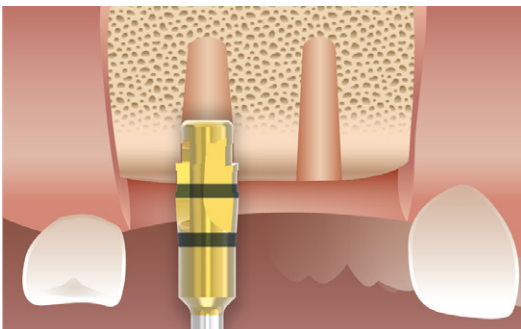

Cortical Drill Ø4.6 (Implant Ø4.5)
Finalize the osteotomy for the IB-T Ø4.5 implant, with the Cortical Drill Ø4.6.

*In dense bone(D1-D2)

Drill to the full depth of the depth indication line.

*In standard or soft bone(D3-D4)

Drill to the beginning of the depth indication line.

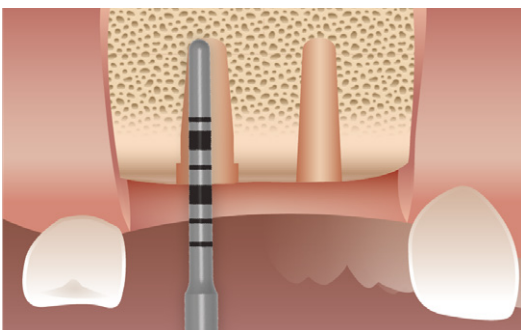

Implant Depth Gauge (Implant Ø4.5)

The marking on the Implant Depth Gauge matches the laser marking on the twist drill.

When measuring the depth after the drilling, the Implant Depth Gauge should be leaned against the wall of the osteotomy.

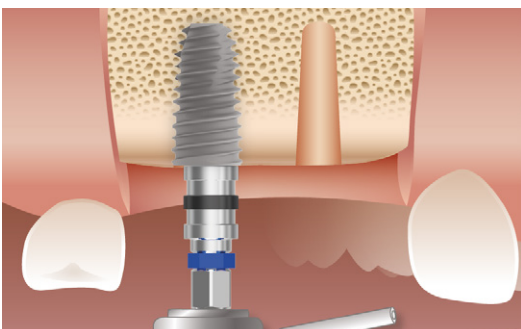

Implant installation (Implant Ø4.5)

Install the implant with a contra angle at low speed (**25-30 rpm**). Set the maximum torque to 30-45 Ncm.

Excessive torque (≥ 50 Ncm) during the fixture placement can have adverse effects, such as partial fracture or bone necrosis.

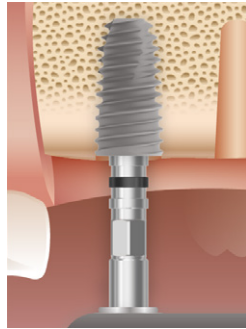
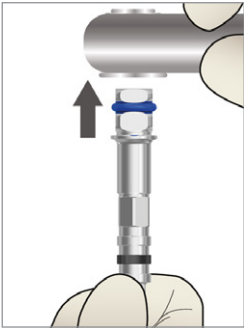

Implant installation continue (Implant Ø4.5)

The Torque Wrench, in combination with the Fixture Driver, may be used for the final manual seating of the implant.

The torque wrench connector should be tightened at the bottom of the torque wrench.

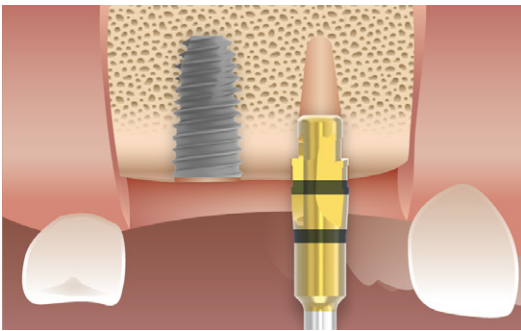

Cortical Drill Ø4.2 (Implant Ø4.0)

Finalize the osteotomy for the IB-T Ø4.0 implant, with the Cortical Drill Ø4.2.

*In dense bone(D1-D2)

Drill to the full depth of the depth indication line.

*In standard or soft bone(D3-D4)

Drill to the beginning of the depth indication line.

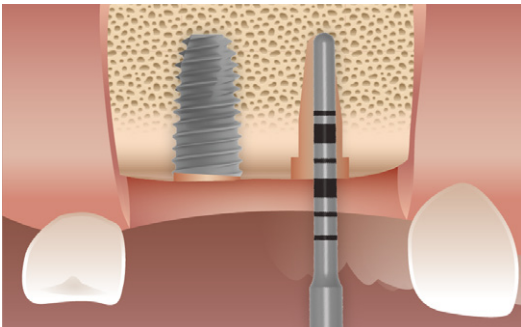

Implant Depth Gauge (Implant Ø4.0)

The marking on the Implant Depth Gauge matches the laser marking on the twist drill.

When measuring the depth after the drilling, the Implant Depth Gauge should be leaned against the wall of the osteotomy.

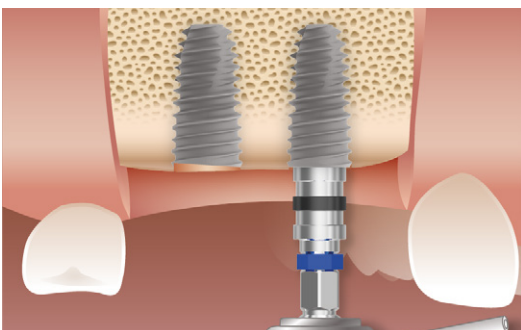

Implant installation (Implant Ø4.0)

Install the implant with a contra angle at low speed (**25-30 rpm**). Set the maximum torque to 30-45 Ncm.

Excessive torque ($\geq 50\text{Ncm}$) during the fixture placement can have adverse effects, such as partial fracture or bone necrosis.

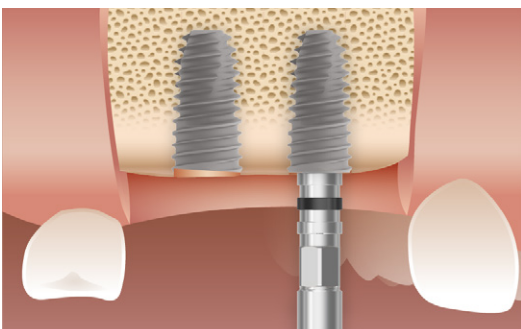

Implant installation continue (Implant Ø4.0)

The Torque Wrench, in combination with the Fixture Driver may be used for the final manual seating of the implant.

One-Stage Procedure

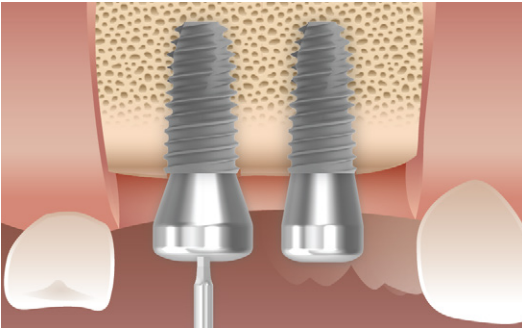

Healing Abutment

Using light finger force (8-10 Ncm), seat the Healing Abutment.

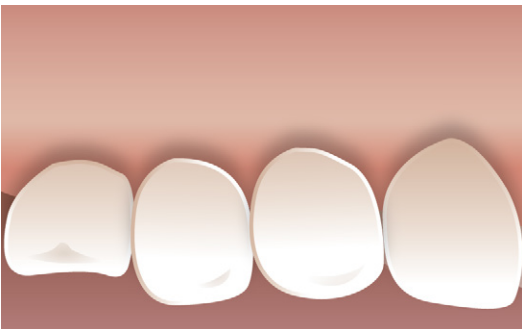

Temporary abutment

Optional:

A one-stage surgical procedure may include a temporary prosthetic restoration.

Two-Stage Procedure

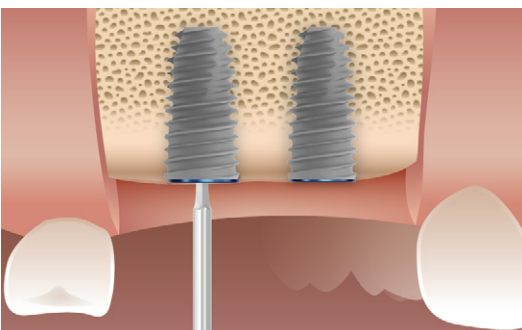

Installation of Cover Screw

Insert the Cover Screw into the implant and tighten with only light finger force .

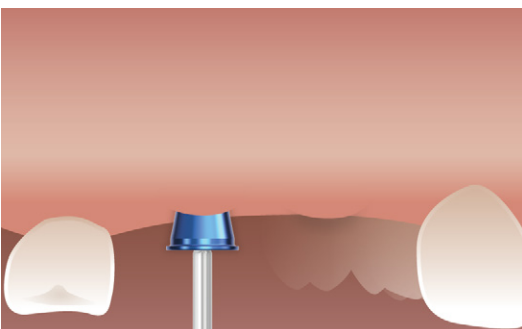







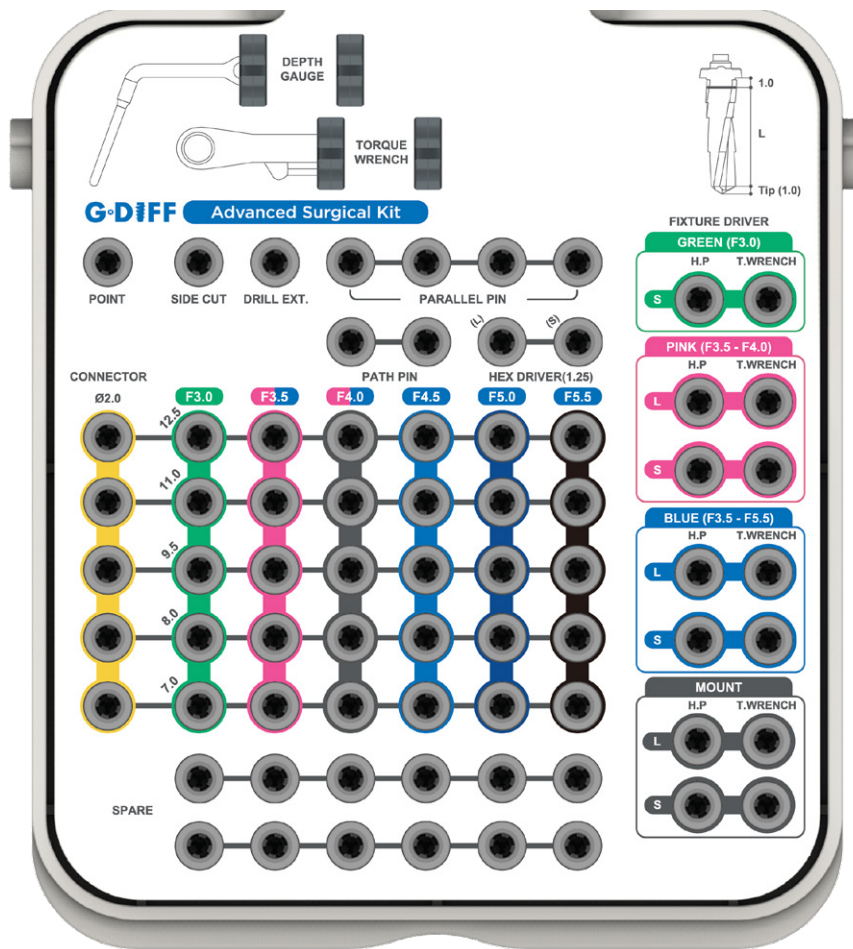









Remove Cover Screw



After an appropriate healing phase the Cover Screw is exposed and removed using the Hex driver(1.25).

G-DIFF Advanced Surgical Kit



Kit Contents

- Point Drill 
- Side Cut Drill 
- Step Drill
 -  Ø2.0
 -  Ø3.0
 -  Ø3.5
 -  Ø4.0
 -  Ø4.5
 -  Ø5.0
 -  Ø5.5
 (L: 7.0, 8.0, 8.5, 9.5, 11.0, 12.5)
- Drill Extension 
- Parallel Pin 
- Path Pin 
- Fixture Driver (Handpiece)  (Long, Short)
 (Short)
- Fixture Driver (Torque Wrench)  (Long, Short)
 (Short)

- Hex Driver (1.25)  (Long, Short)
- Depth Gauge 
- Torque Wrench 

* Optional Item

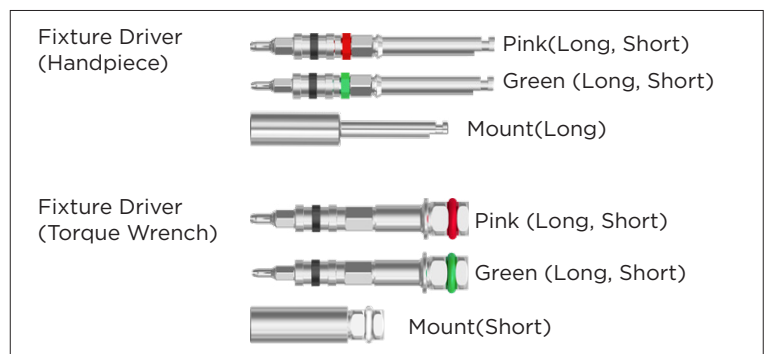

Drilling Protocol -Advanced Surgical Kit

Ø3.0x9.5mm (1,000 RPM / 30~45N·cm)

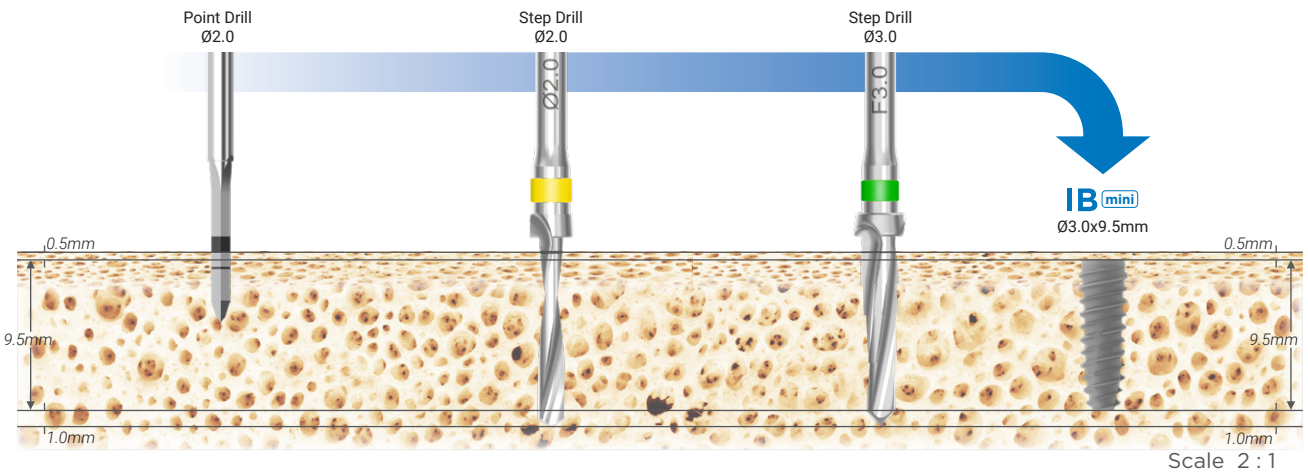

Ø3.5x9.5mm (1,000 RPM / 30~45N·cm)

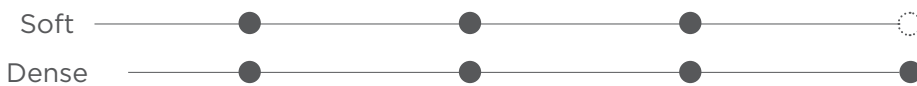
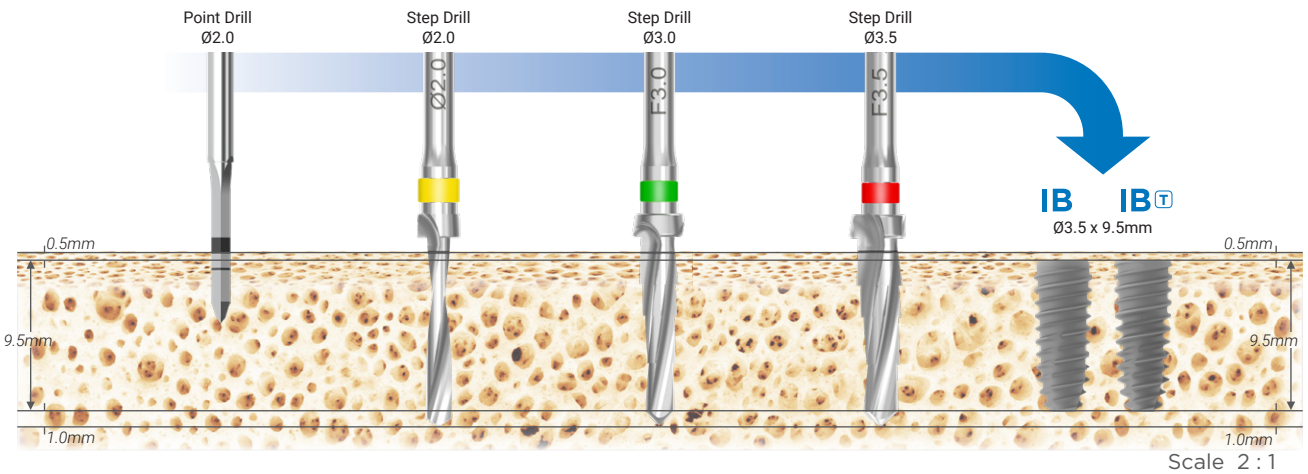

Ø4.0x9.5mm (1,000 RPM / 30~45N·cm)

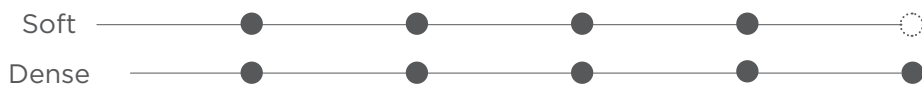
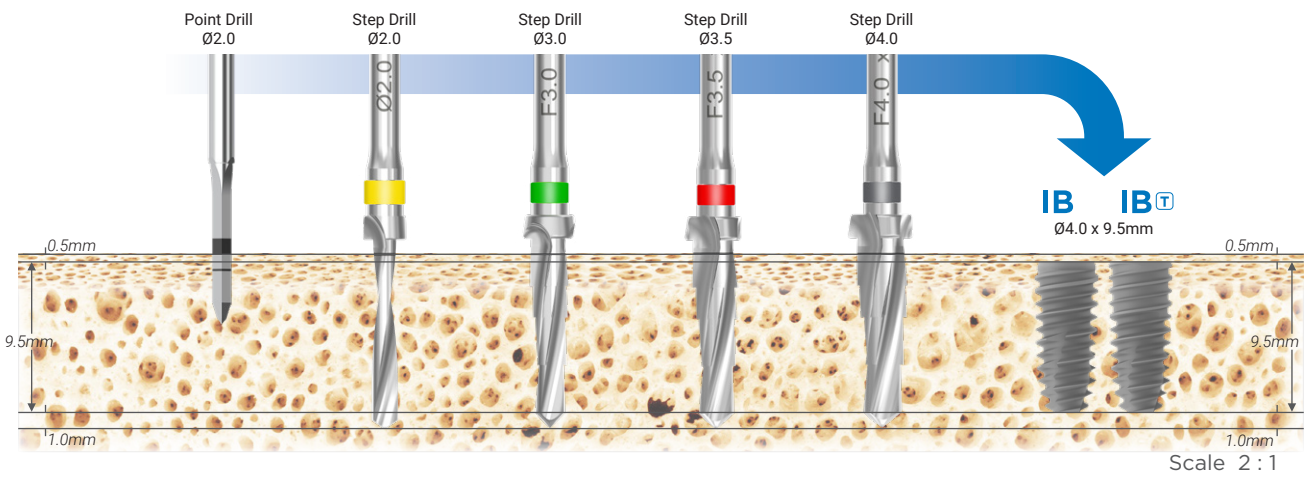

Ø4.5x9.5mm (1,000 RPM / 30~45N·cm)

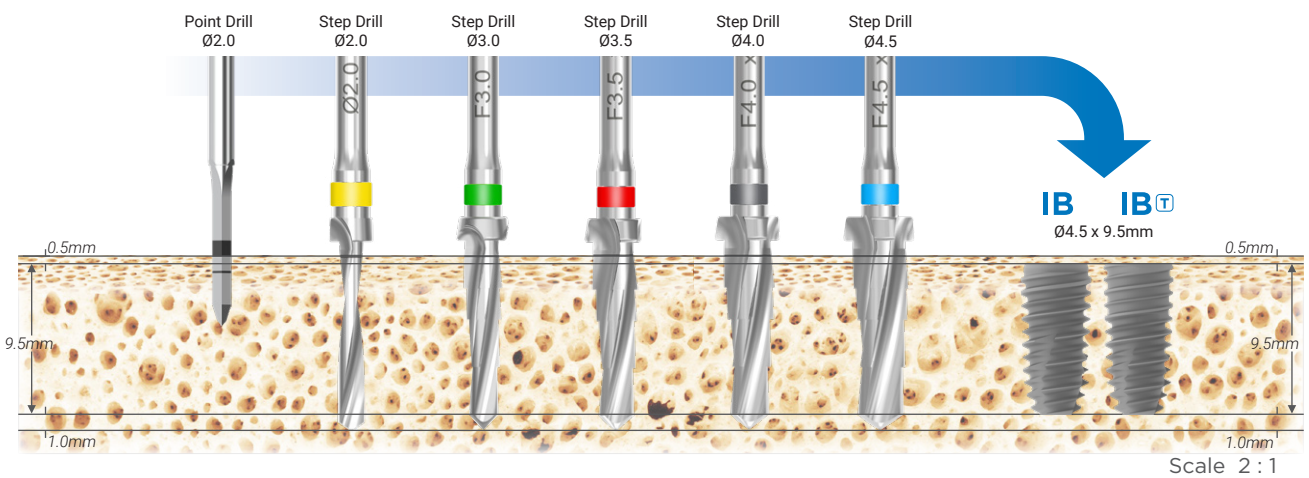

Ø5.0x9.5mm

(1,000 RPM / 30~45N·cm)

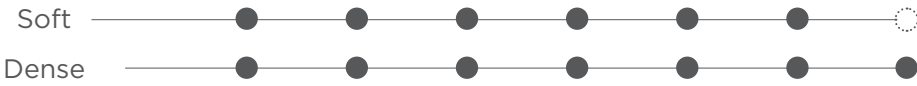
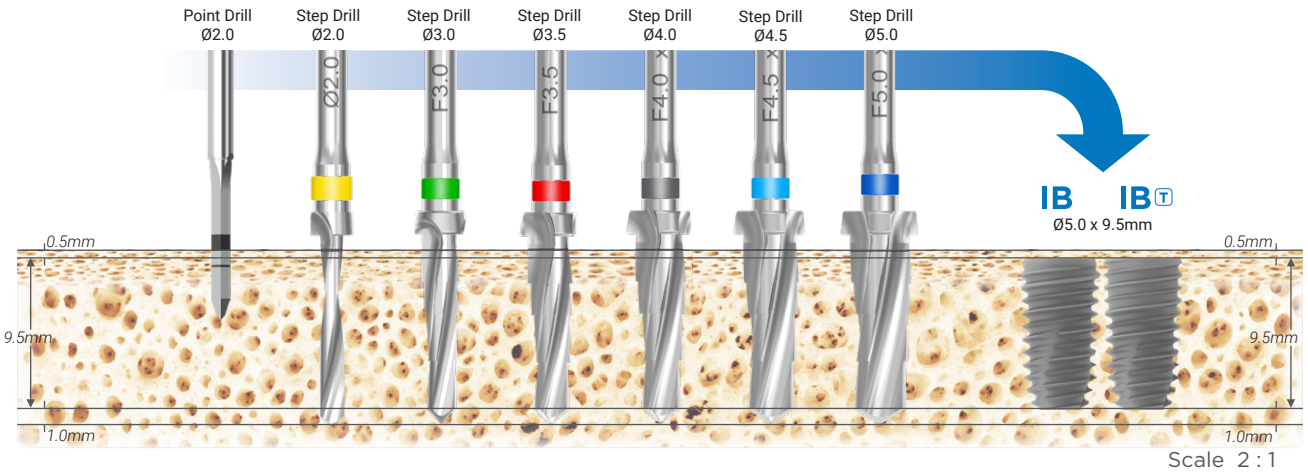

Ø5.5x9.5mm



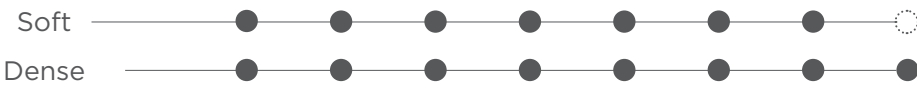
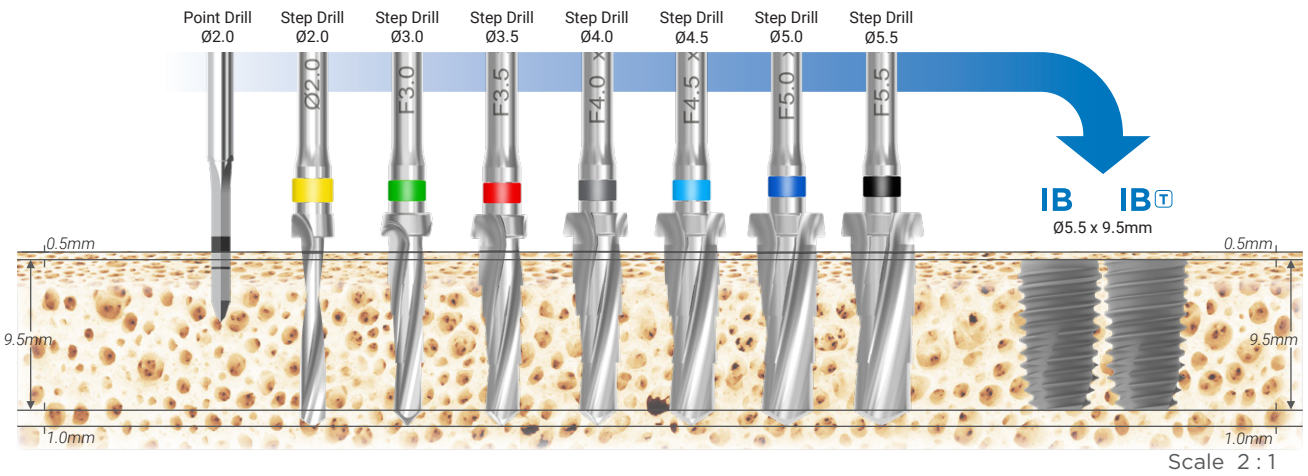



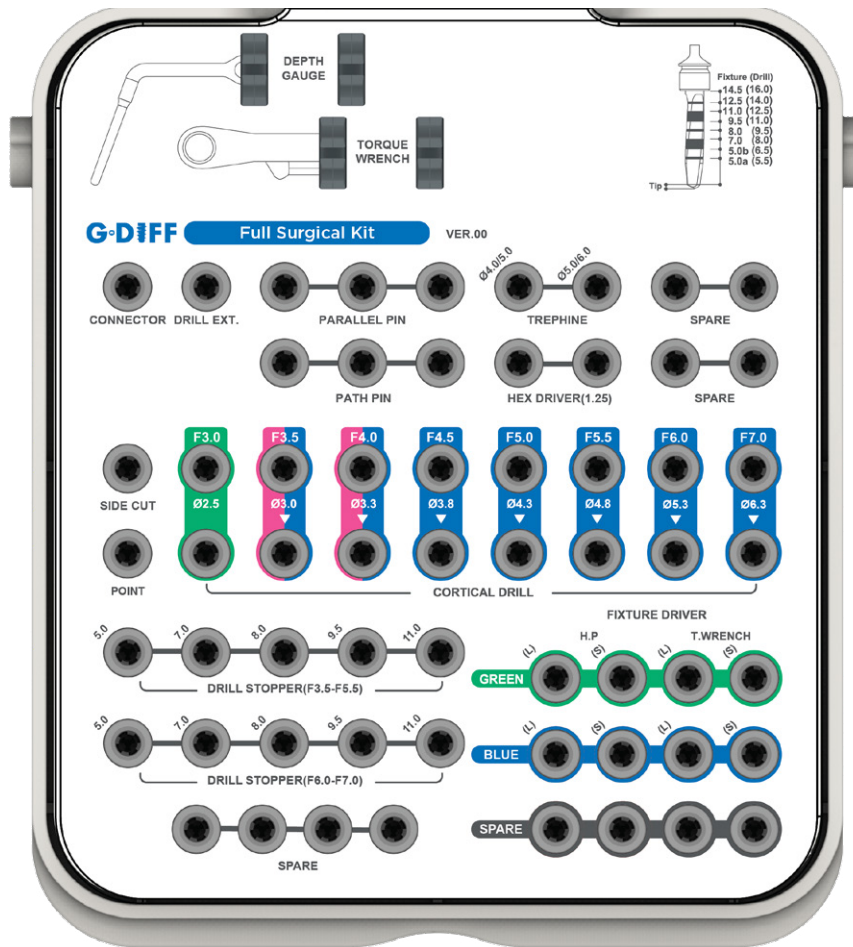









(1,000 RPM / 30~45N·cm)



G-DIFF Full Surgical Kit

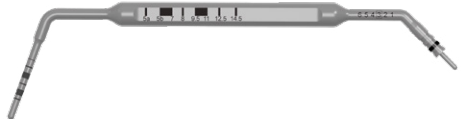

Kit Contents

- Point Drill 
 - Side Cut Drill 
 - Twist Drill  (Ø2.5, Ø3.0, Ø3.3, Ø3.8, Ø4.3, Ø4.8, Ø5.3, Ø6.3)
 - Cortical Drill  (Ø3.1, Ø3.7, Ø4.2, Ø4.6, Ø5.0, Ø5.5, Ø6.0, Ø7.0)
 - Drill Stopper  (L5.0, L7.0, L8.0, L9.5, L11.0)
 - Trephine Bur  (Ø4.0/5.0, Ø5.0/6.0)
 - Drill Extension 
 - Parallel Pin 
 - Path Pin 
 - Fixture Driver (Handpiece)  (Long, Short)
 - Fixture Driver (Torque Wrench)  (Long, Short)
 - Hex Driver (1.25)  (Long, Short)
 - Depth Gauge 
 - Torque Wrench 
- * Optional Item
- Fixture Driver (Handpiece)  (Long, Short)
 - Fixture Driver (Torque Wrench)  (Long, Short)

Drilling Protocol - Full Surgical Kit

Please refer to P.7-9 for $\varnothing 3.0$ - $\varnothing 5.5$ Fixture's drilling protocol.

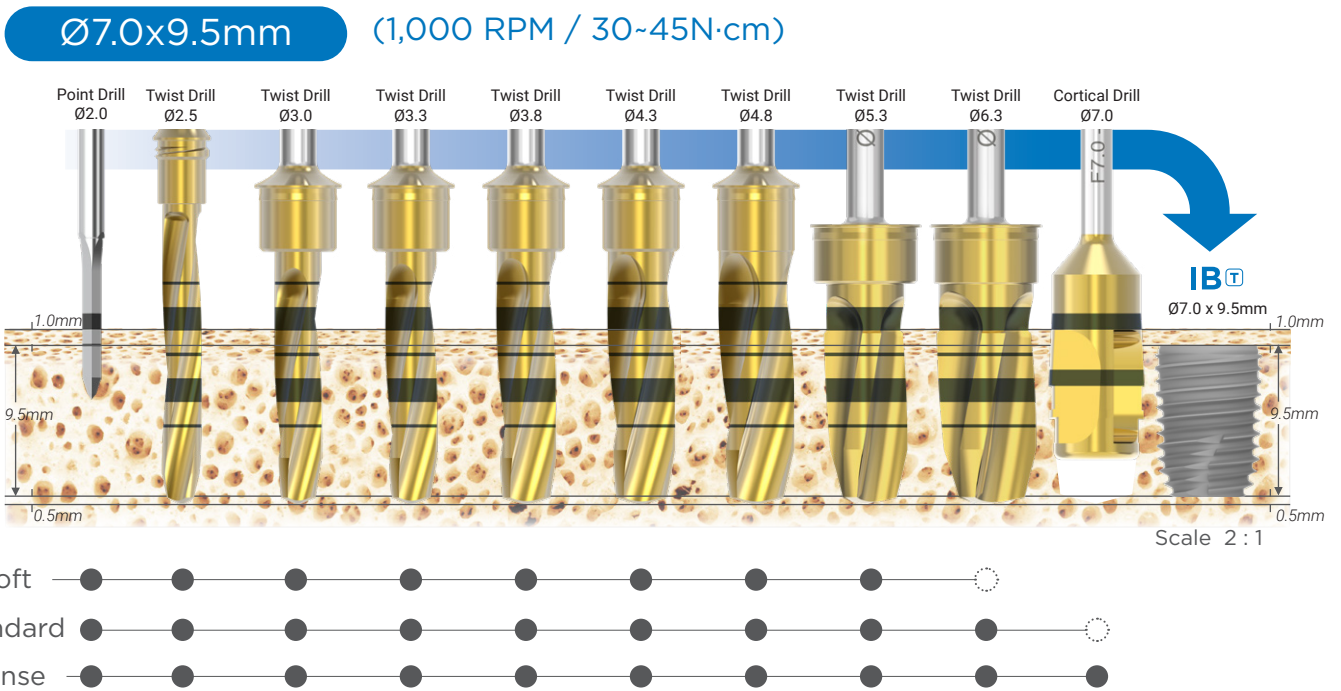
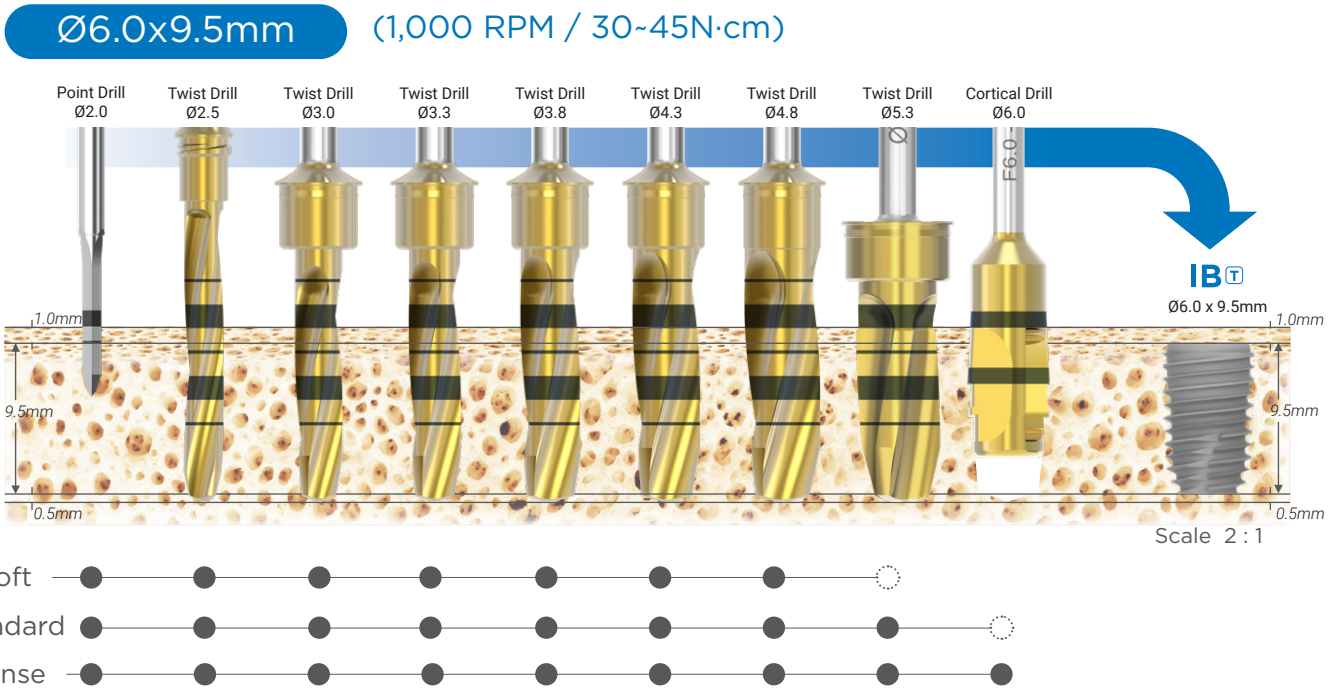

Pre-Operative Procedures

Introduction

These instructions were designed to serve as a reference guide for dental clinicians to utilize IB and IB-T implant system.

IB and IB-T implant systems are implants that have been developed to meet the diverse needs of patients and allow the practitioner to choose a stable surgical technique that meets their needs.

The implant designs allow clinicians to place implants in the edentulous or partially edentulous mandibular or maxilla to support fixed and detachable bridge work or single tooth crown.

Preoperative Examination and Planning

Preoperative examinations should include a general assessment of the patient's health, clinical and oral radiography. Factors such as excessive smoking, chewing patterns, and alcohol consumption should also be considered.

Radiographic analysis should be used to assess bone quality and osteoporosis. Initial radiological evaluation, in combination with clinical examination, are the basis for determining whether a patient is a candidate for implant treatment.

The upper and lower teeth model should be mounted on the articulator, there must be a relationship between the alveolar ridge and the studied tooth. Diagnostic wax-ups that replace missing teeth should be made in the model.

Computer Guided Treatment software can also help to ensure accurate planning for optimal implant placement.

Before starting treatment, the patient should be informed about the results of the preoperative examination. In addition, a clear explanation must be given in advance of the expected outcome and the risks associated with the operation.

Bone Density

The protocol described in this manual was developed to provide information on drill selection when drilling at various bone densities. However, this protocol is only a standard guideline and the clinician is responsible for assessing the bone density of the anatomy when determining the appropriate protocol.

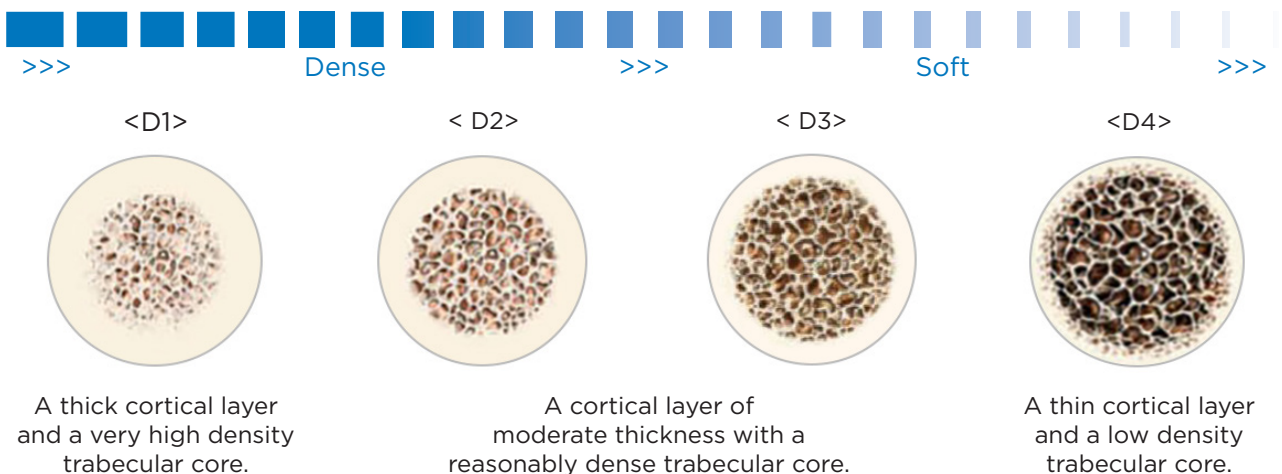

Implants & Drills Overview

Implants – Intended use & consideration

It is used to replace missing teeth in single or multiple in the mandible or maxilla. Dental implant procedures involve complex dental procedures, so proper training of the procedure is recommended before use.

Clinicians should consider occlusion and loading conditions when determining the number and spacing of implants. Excessive placement torque may lead to mechanical or biological failure due to bone compression and necrosis.

In terms of mechanical strength, it is advantageous to place the implant as wide as possible especially important in the posterior region.







****Caution :** Federal law restricts this device to only be sold by or on the order of a licensed dentist.

Drills – Intended use

In order to ensure efficient and traumatic free expansion of the implant placement site, it is prepared in a step-by-step procedure using a drill of the right diameter for the implant size.

All drilling of bone is done using appropriate drilling techniques with saline, preventing the bones from heating up.

Drill types

- Point drill 
-To mark and create insertion point for implant placement.
- Side Cut Drill 
-To laterally reposition the initial osteotomy created with Point or Twist drill.
- Twist drill 
-To Prepare the implant installation site to reach the final width and depth.
- Pilot drill 
-Optional drill for small diameter implant in soft bone situation.
- Cortical drill 
-To enlarge the cortical bone to reduce bone pressure around the implant platform.
- Step drill 
-To enlarge drill holes to match the shape of the implant to reduce bone pressure around the implant platform.
- Trepine bur 
-To remove bone or dental implants.

Relation between Fixture & Drill Depth

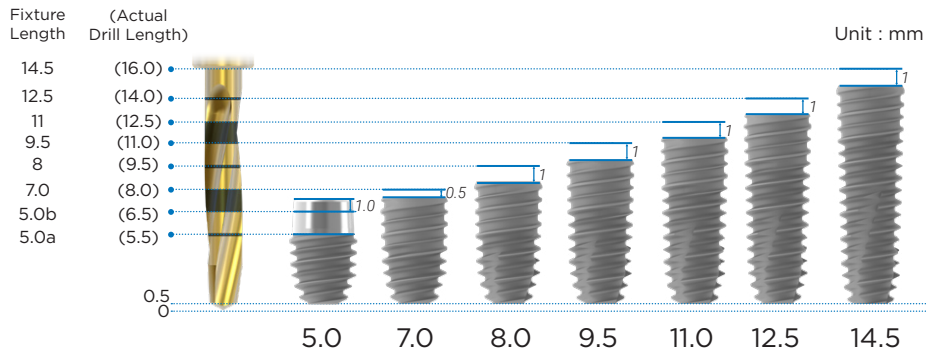

Relation between Drill and Drill stopper

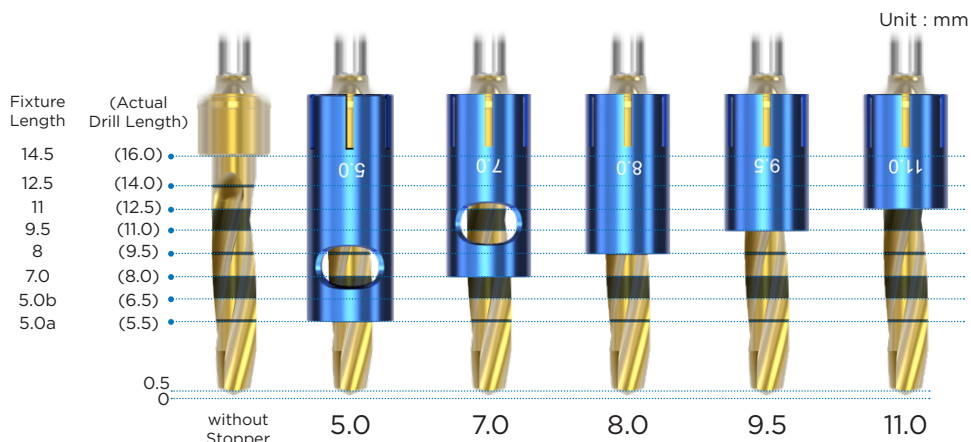

*Extra long drill stopper is available upon request

Implant Depth Gauge

The marking on the Implant Depth Gauge matches the laser marking on the twist drills.

When measuring the depth after the drilling, the Implant Depth Gauge should be leaned against the wall of the osteotomy.

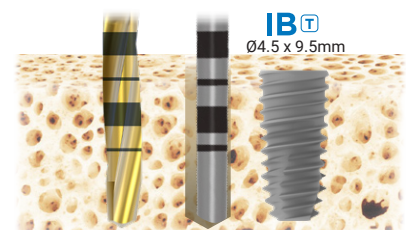

Preparation - Package Opening -Mountless type



Color-Coding

For easy identification of the implant-abutment connection size the product packaging is color-coded:

- Blue Connection
IB-T Ø3.5-Ø7.0, **IB** Ø4.5-Ø5.5, **IB-MT** Ø3.5-Ø5.0
- Pink Connection
IB-T Ø3.5, **IB** Ø3.5-Ø4.0
- Green Connection
IB mini Ø3.0

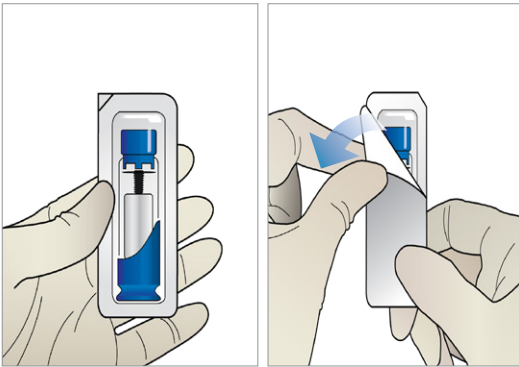

Open a Blister Box

Peel off the paper cover slowly to take out the ampule from the blister box.

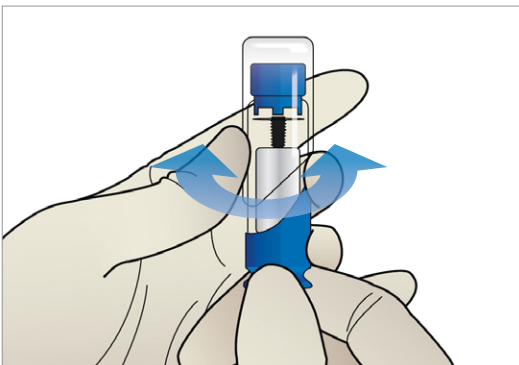

Open a Ampule

Turn the ampule and lift the lid up slowly.



Open a Cap

Open the cap of ampule.

**Caution : When Opening the cap, Hold the fixture ampule upward.



Implant Pick up

Attach the Fixture Driver to the contra angle and seat into the fixture.

**The Fixture Driver MUST be connected firmly with internal hex of the fixture.

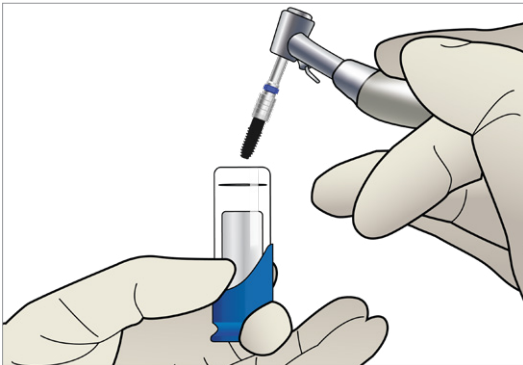
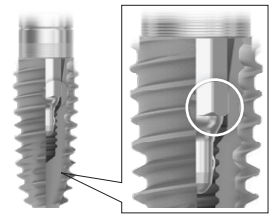

Deliver & Install

Pull the Fixture Driver to take out the fixture from the ampule.

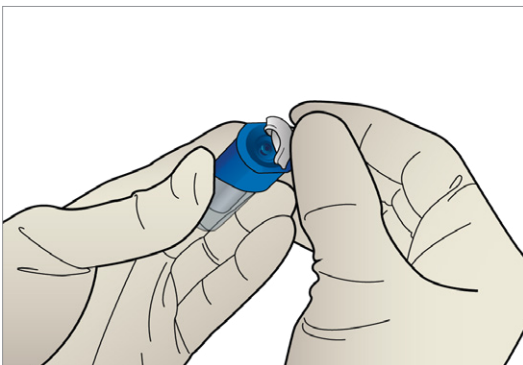

Cover Screw

Lift the lower cap from the ampule.

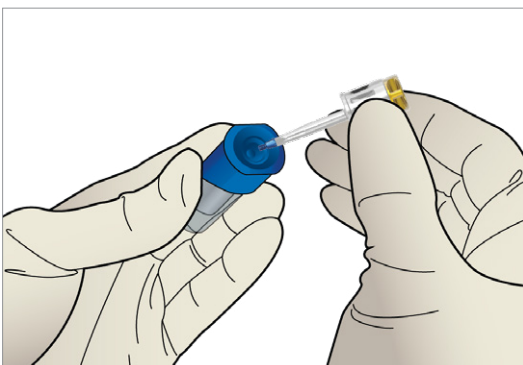

Cover Screw

Pick it up with a Hex Driver(1.25) and install it into the fixture.

Preparation - Package Opening -Mount type



Color-Coding

For easy identification of the implant-abutment connection size the product packaging is color-coded:

- Blue Connection
IB-T Ø3.5-Ø7.0, **IB** Ø4.5-Ø5.5, **IB-MT** Ø3.5-Ø5.0
- Pink Connection
IB-T Ø3.5, **IB** Ø3.5-Ø4.0
- Green Connection
IB mini Ø3.0

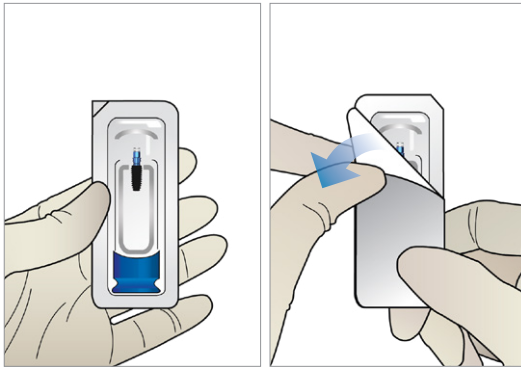

Open a Blister Box

Peel off the paper cover slowly to take out the ampule from the blister box.

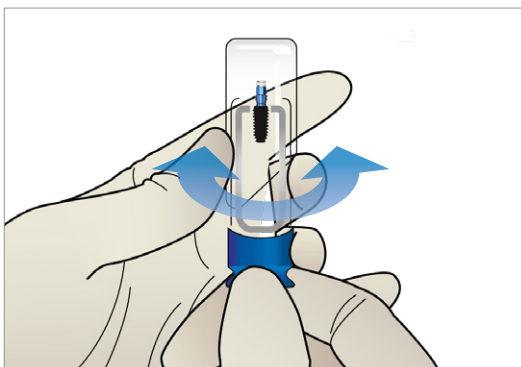

Open a Ampule

Turn the ampule and lift the lid up slowly.



Implant Pick up

Attach the Fixture Driver(mount type) into the mount.

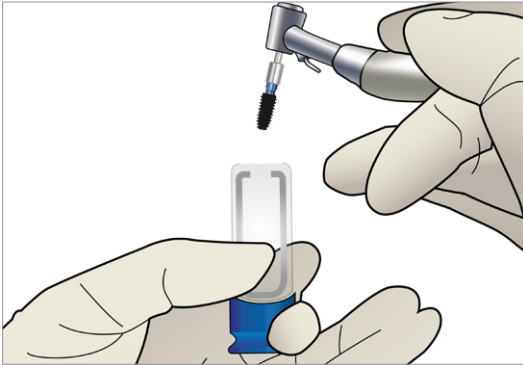

Deliver & Install

Pull the Fixture Driver to take out the fixture from the ampule.

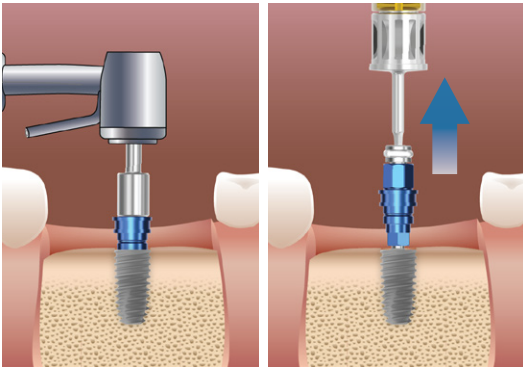

Deliver & Install

Install the Fixture with a Contra Angle.

After fixture placement, Separate the mount screw first using the Hex driver (1.25).

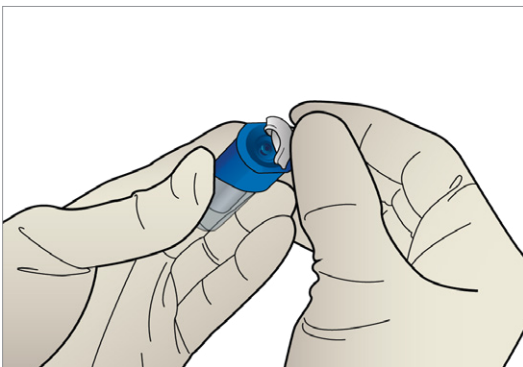

Cover Screw

Lift the lower cap from the ampule.

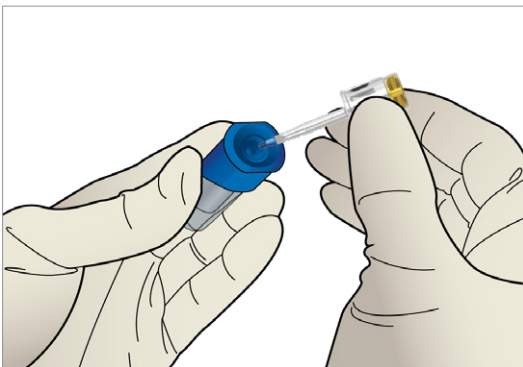

Cover Screw

Pick it up with a Hex Driver(1.25) and install it into the fixture.

Sterilization and Instrument Care

Please follow legal regulations, as well as hygienic guidelines to prevent contamination and infection through prevention.

It is important to use and follow proper cleaning, disinfection and sterilization procedures.

Sterilization

- The Drills and Surgical Instruments are non-sterile. Sterilize before each use, either using pre-vacuum or gravity in an autoclave. Please avoid sterilizing plastic products at temperatures exceeding 170°C(= 338°F). Remove the inner packaging from the tray before sterilization and disassemble the assembled components, if any, to increase the sterilization efficiency. Before sterilizing the tray, wrap it with a surgical drape and seal it with an autoclave tape.

Autoclave Type	Gravity	Pre-Vacuum
Set Point Temperature	132°C / 270°F	132°C / 270°F
Exposure Time	15 min	4 min
Drying Time	30 min	30 min

Usage of Drills

- During the process of drilling, the handpiece must be moved in a vertical pumping motion, and saline must be injected to reduce the friction heat between the drill and the bone.
- Laser markings on the drill indicate the depth and must be understood before use.
- The recommended number of uses per drill is 40, but a drill should not be used when its cutting force is reduced.
 - * Since the durability of the drill varies depending on many factors, such as bone density of the patient, be sure to check the drill condition before every use.

Cleaning and Storage after Use

- Drills and surgical instruments:
 1. Immediately after use, remove all instruments from the tray, disassembling the assembled components, if any, and soak them in alcohol and rinse.
 2. Wash off remaining bloodstains and debris with distilled water or under running tap water and cleanse the parts difficult to reach using a syringe or pipe cleaner.
 3. In compliance with the manufacturer's instructions, perform ultrasonic cleansing for 10 min with an enzyme cleaning solution diluted in tap water and rinse under running tap water for 3 min.
 4. Remove moisture completely with a dry cloth or hot-air dryer.
- Kit tray:
 1. Remove debris using a soft brush with distilled water or under running tap water and cleanse the parts difficult to reach using a syringe or pipe cleaner.
 2. In compliance with the manufacturer's instructions, soak the tray for 1 min in an enzyme cleaning solution diluted with tap water and remove remaining debris using a soft brush. Rinse it under running tap water for 3 min.
 3. Remove moisture completely with a dry cloth or hot-air dryer.

Put the completely dried surgical instruments back in the kit case and sterilize according to the manufacturer's instructions.

- Do not leave the product unguarded in a contaminated place or a place at risk of infection.
(To prevent contamination and infection, comply with hygiene guidelines and adhere to all relevant laws and regulations of the country of the receiving side.)
- As this medical device is non-sterile, sterilize it in an autoclave before and after each use.



ACH Medical Co., Ltd.

28, Namyang-ro 930beon-gil, Namyang-eup,
Hwaseong-si, Gyeonggi-do, Rep.of Korea, 18255
TEL +82-31-355-7110 FAX +82-31-355-6759

Copyright ACH Medical., Ltd. All Rights Reserved.

GSM-2208-REV03